

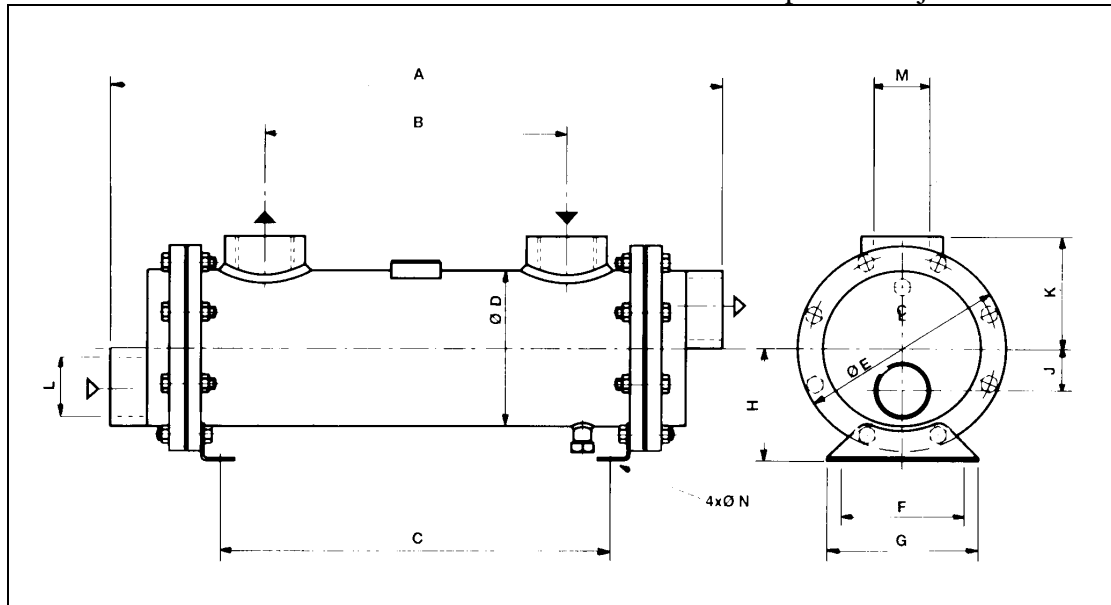

6. STAINLESS STEEL HEAT EXCHANGERS

Stainless steel heat exchangers are particularly useful in bad water environments caused by pollution or from the chemicals used to counter it. They can also be used to overcome the corrosive nature of some synthetic oils and refrigerants. The shell side usually contains the process fluid with cooling water on the tube side. The heat exchangers should be installed horizontally as shown below, and if preferred the mounting feet can be turned through 90 degrees. The end covers can be removed should it be necessary to clean the inside of the tubes. All the heat exchangers are available with either three pass (as illustrated) or single pass end covers. Single pass should only be used when the tube side flow is much larger than the shell side. If the two flow rates are similar, three pass flow will give better performance. We can select by computer the optimum size of heat exchanger and if necessary multiple units can be connected together in series or parallel, as appropriate. For liquids which would not evaporate at the operating temperature and atmospheric pressure the maximum working pressure for these heat exchangers is 30 bar and the maximum working temperature is 200° C.



	A	B	C	D	E	F	G	H	J	K	L	M	N
	mm	mm	mm	mm	mm	mm	mm	mm	mm	mm	BSP	BSP	mm
SB 4507-2	460	266	310	89	136	60	90	75	22	75	G1	G1	9
SB 4507-4	734	540	584	89	136	60	90	75	22	75	G1	G1	9
SB 4507-6	1114	920	964	89	136	60	90	75	22	75	G1	G1	9
SC 4508-4	764	520	584	114	160	80	110	90	28	85	G1¼	G1¼	9
SC 4508-6	1144	900	964	114	160	80	110	90	28	85	G1¼	G1¼	9
SC 4508-8	1652	1408	1472	114	160	80	110	90	28	85	G1¼	G1¼	9
SD 4509-4	764	510	584	141	194	100	130	105	35	105	G1½	G1½	11
SD 4509-6	1134	890	964	141	194	100	130	105	35	105	G1½	G1½	11
SD 4509-8	1652	1398	1472	141	194	100	130	105	35	105	G1½	G1½	11
SE 4510-4	804	490	584	168	220	130	160	120	45	120	G2	G2	11
SE 4510-6	1184	870	964	168	220	130	160	120	45	120	G2	G2	11
SE 4510-8	1692	1378	1472	168	220	130	160	120	45	120	G2	G2	11
SE 4510-9	2200	1886	1980	168	220	130	160	120	45	120	G2	G2	11
SF 4511-4	834	470	574	219	284	180	220	150	60	150	G2½	G2½	14
SF 4511-6	1214	850	954	219	284	180	220	150	60	150	G2½	G2½	14
SF 4511-8	1722	1358	1462	219	284	180	220	150	60	150	G2½	G2½	14
SF 4511-9	2230	1866	1970	219	284	180	220	150	60	150	G2½	G2½	14
SG 4512-4	844	430	574	273	340	250	290	180	70	180	G3	G3	14
SG 4512-6	1224	810	954	273	340	250	290	180	70	180	G3	G3	14
SG 4512-8	1732	1318	1462	273	340	250	290	180	70	180	G3	G3	14
SG 4512-9	2240	1826	1970	273	340	250	290	180	70	180	G3	G3	14